

The WP-2000, Weatherproof Duct Detector Enclosure, is for use with an SL-2000 Series Conventional Duct Detector. The enclosure offers outdoor protection of a SL-2000 Conventional Duct Detector from rain, sleet and snow or indoor protection from dripping water



### Features

- 16 Gauge Steel
- Drip Shield Top
- Slip-on Removable Cover
- Embossed Mounting Holes

### Listings and Approvals

## Installation Diagram

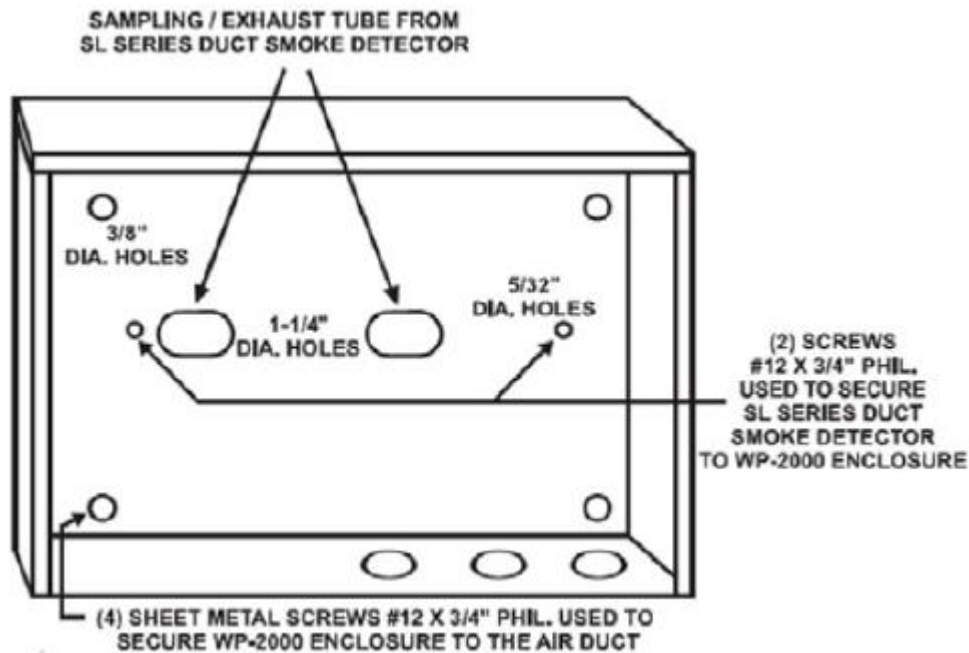

## Specification

Dimensions	11.06" H x 18.13" W x 4.38" D
Knockouts	3 bottom, convertible 0.75" to 1.75"
Metal	16 gauge CRS
Access	2 screws, removable cover
Protection Rating	3R - UL 50, NEMA and CSA
Temperature	See SL-2000 series data sheet

## Order Codes and Options

WP-2000	Weatherproof Duct Detector Enclosure
---------	--------------------------------------

[Check if this document is up to date](#) | [Give us feedback](#)

Advanced, 100 South Street, Hopkinton, MA. 01748 T: +508 435 9995 E: [usa@advancedco.com](mailto:usa@advancedco.com) W: [us.advancedco.com](http://us.advancedco.com)

As our policy is one of constant product improvement the right is therefore reserved to modify product specifications without prior notice.