

## EL/RL/240 Hold-Off Relay

On some installations, it can sometimes be more advantageous to provide the emergency lighting from static inverter or central battery system. On systems using static inverters, it is sometimes necessary for the normal supply and static inverter supply to be selected automatically by a switching device either within or external to the luminaire.

The EL/RL/240 hold off relay provides a simple solution to this requirement. When a site uses a static inverter, it is not always tied to the grid frequency and could even be antiphase with the normal supply. When a relay tries to switch between these supplies there is a tendency for the relay to suffer from arcing between the normally open and normally closed contacts resulting in temporary short circuit between the two out of phase supplies. This will cause external circuit protection to operate.

Because the device uses two interposing relays for the two supplies and introduces a time delay of approximately 500mS between breaking the normal supply and connecting the static inverter supply, the device removes any risk of arcing across contacts due to phase differences between the two supplies. This is also reversed when the static inverter supply is removed and a similar delay is introduced prior to reconnection to the normal lighting supply.

A dimming isolation facility is incorporated as standard for use with dimming ballasts to enable full light output to be achieved in the emergency condition.



### Features

- Enhanced change-over relay for static inverter supplied luminaires
- Automatic time delay to avoid arcing during change-over
- Built in dimming isolation feature

### Specification

Supply Voltage	230Volt (220-240V) at 50Hz
Supply Current	18mA
Temperature Range	0 to 70°C
Relays	2 * DPCO and 1 * SPCO
Time Delay on change-over	500mS (approx.)
Relay Rated Voltage	240V AC
Relay Rated Current	4A (Maximum)
Dimensions (H*W*L)	32 * 42 * 160 (mm)
Fixing centres (mm)	152

### Order Codes and Options

EL/RL/240:	Enclosed hold-off relay with built-in delay
------------	---

## Dimensions

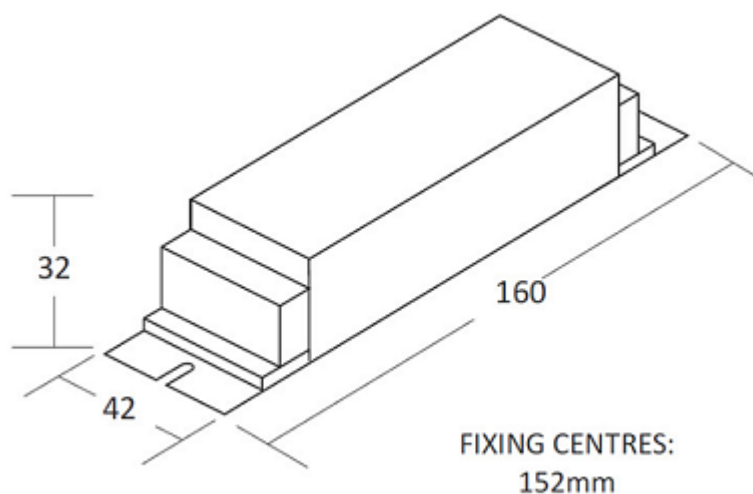

## SCHEMATIC

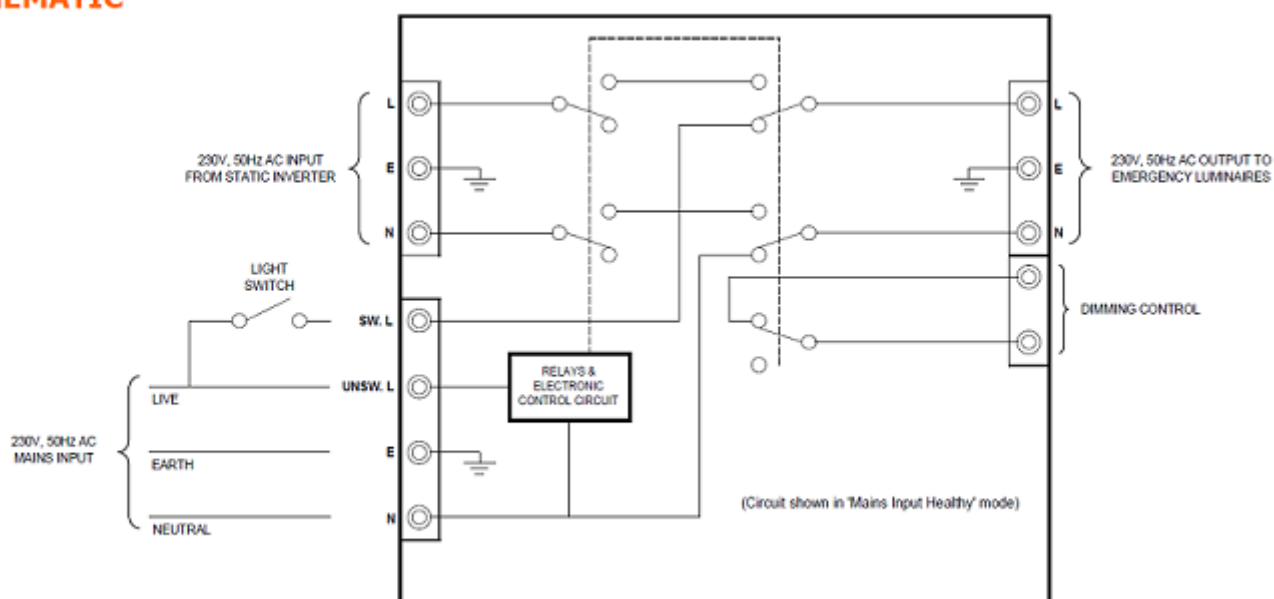

[Check if this document is up to date](#) | [Give us feedback](#)

Advanced, The Bridges, Balliol Business Park, Newcastle, NE12 8EW, UK T: +44 (0)1670 707 111, E: [enquiries@luxintelligent.com](mailto:enquiries@luxintelligent.com), W: [www.luxintelligent.com](http://www.luxintelligent.com)

As our policy is one of constant product improvement the right is therefore reserved to modify product specifications without prior notice.