

Intelligent Sounder Base - obsolete

The intelligent sounder base is a low profile base sounder which is designed around a fully digital protocol and has a 240 device loop capacity.

Once installed onto a compatible loop the device is fully addressable and benefits from an extensive range of intelligent functionality, including sounder synchronisation.

The unit's integral detector base has easy access for loop cabling and allows for the connection of both the sounder and associated detector via a single set of cable terminations.



Features

- 32 programmable tones
- Built-in loop isolators
- Fully intelligent
- Synchronised sounder
- Adjustable volume output
- Auto-addressable
- Programmable via device programming tool
- Includes device identification tab
- Easy central cable entry
- Low profile design

Standards and Approvals

- EN54-3:2001 +A1:2002 +A2:2006
- Approved by BRE/LPCB and certified by the UAE Civil Defence

Specification

| | |
|-------------------------------|----------------|
| Power supply | 15V to 32Vdc |
| Max humidity (non condensing) | 95% RH |
| Operating temperature range | -10°C to +55°C |
| Dimensions (W x D) | 116 x 42 mm |
| Weight | 188 g |
| Current consumption | 4-7 mA |
| 32 tone range | 440 - 2900 Hz |
| Max volume @ 1m | 94 dB |

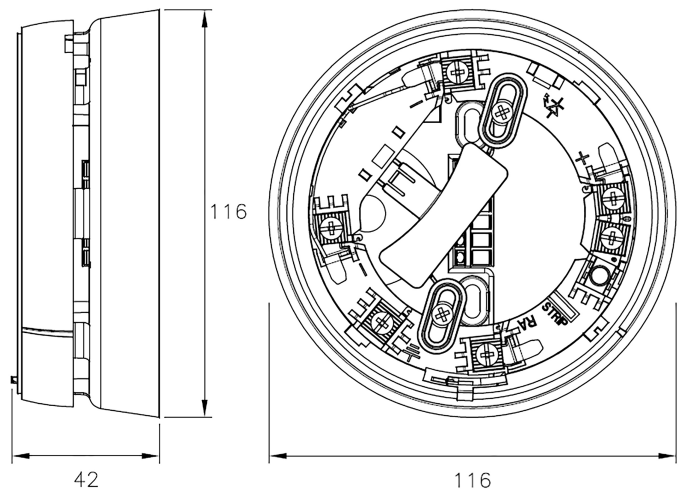

Order Codes and Options

Axis-SMB

Intelligent Sounder Base

[Check if this document is up to date](#) | [Give us feedback](#)

Advanced, The Bridges, Balliol Business Park, Newcastle upon Tyne, NE12 8EW, UK **T:** +44 (0)345 894 7000, **E:** enquiries@advancedco.com,
W: www.advancedco.com

As our policy is one of constant product improvement the right is therefore reserved to modify product specifications without prior notice.