

Conventional Zone Module

The AX-CZM Conventional Zone Module can be monitored and controlled by an Axis AX fire alarm control panel (P-BUS, “Peripheral Bus” operating mode), or by any UL864 listed fire alarm control panel (“Standalone” operating mode).

The AX-CZM module provides monitoring of up to eight (8) Class B conventional zone circuits with a programmable end-of-line resistor (6.8K, 4.7K, or 3.9K), or four (4) Class A conventional zone circuits. In addition, each AX-CZM module has three (3) Form C relay contacts defaulted in “Standalone” operating mode as an alarm, trouble and if required, earth/ground fault condition on a per module basis. If used in the “Peripheral Bus” mode of operation, these three (3) Form C relay contacts are freely programmable for any system functionality.

When connecting the AX-CZM module(s) to an Axis AX panel (“Peripheral Bus” operating mode), up to sixteen (16) AX-CZM modules can be supported. By supporting sixteen (16) AX-CZM modules, an Axis AX panel can accommodate up to 128 Class B (64 Class A) conventional zones and 48 (Form C) relay contacts. When used in the “Peripheral Bus” mode of operation, all zone and relay functionality is fully field programmable using the powerful cause and effect rules of Advanced’s PC-NeT field configuration program.

In the “Peripheral Bus” or “Standalone” operating modes, the AX-CZM module must be powered by a UL-Listed 24 VDC nominal power supply and mounted inside an Advanced AXM-009 peripheral bus enclosure. In the “Standalone” mode of operation, the host (ANSI/UL 864 Listed) fire alarm control panel would monitor the single alarm, trouble (alarm and trouble contacts are common for all eight zones) and if required, earth/ground fault contacts for AX-CZM module status.

Each AX-CZM module makes use of Advanced’s software monitoring and real-time power management (SMART-PM) techniques to minimise current requirements under alarm conditions across multiple zones. This SMART-PM technology results in lower power consumption, and increased fire alarm control panel battery life. Using the SMART-PM information, each zone circuit is capable of indicating a trouble condition when a 2mA load is exceeded (i.e. too many conventional smoke detectors added to the circuit).

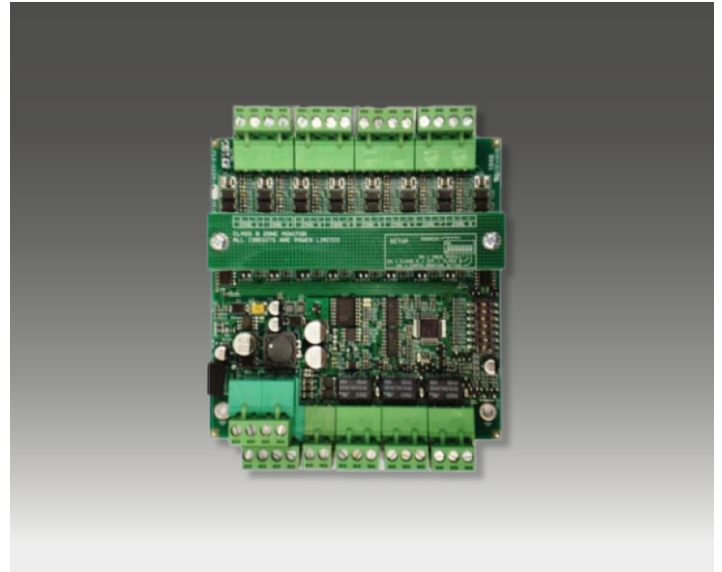

Features

- Axis AX Series P-BUS or Standalone Operation
- Eight Class B or Four Class A Zone Circuits
- Programmable Class B End-of-Line
- P-BUS Operation Supports Sixteen AX-CZM’s
- Three Form “C” Relay Contacts
- Advanced Power Management (SMARTPM)
- Programmable End-of-Line 6.8K, 4.7K or 3.9K
- 50 Ω Initiating Circuit Resistance
- Ideal for Retrofit Applications
- Extensive 2-Wire Detector Compatibility
- Conventional Detector and Contact Device Monitoring
- Programmable Alarm Verification
- P-BUS Supervised Remote Power Supply Monitoring
- 128 Class B (or 64 Class A) Zones and 48 Relays per Axis AX Series Panel
- Removable Terminal Blocks
- Programmable Latching/Non-Latching Input Types

Listings and Approvals

- Certified to UL864 10th Edition – File No. S25235
- CSFM Approved: Pending
- NYCFCO COA: Pending

Specification

Operating Voltage	24 VDC
Operating Current	
Quiescent	110mA (Vs = 24, 8 Zones = Min Load)
Minimum	120mA (Vs = 24, 8 Zones = Max Load, Relays OFF)
Maximum	135mA (Vs = 24V, 8 Zones = Max Load, Relays ON)
Alarm	At Least 318mA (8 Zones = Max Load, 3 Relays ON)
Relays	
Relay 1	"Standalone" Common Alarm
Relay 2	"Standalone" Common Trouble (Fail-Safe)
Relay 3	"Standalone" Earth/Ground Fault
Ratings	1A @ 30 VDC
LEDs	
Red	Relay 1 - "Standalone" Alarm
Green	Relay 2 - "Standalone" Normal
Yellow	Relay 3 - "Standalone" Earth/Ground
Resistors	
Class B EOL	6.8K 4.7K or 3.9K
P-BUS Operation	10K
Remote Power	150K
End-of-Line	
Environment	Indoor, Dry
Operating Temperature	32 °F - 120 °F (0 °C - 49 °C)
Humidity	93% (Non-Condensing)
Weight	5.3 oz
Dimension	4.2" X 5"

Wiring Diagrams

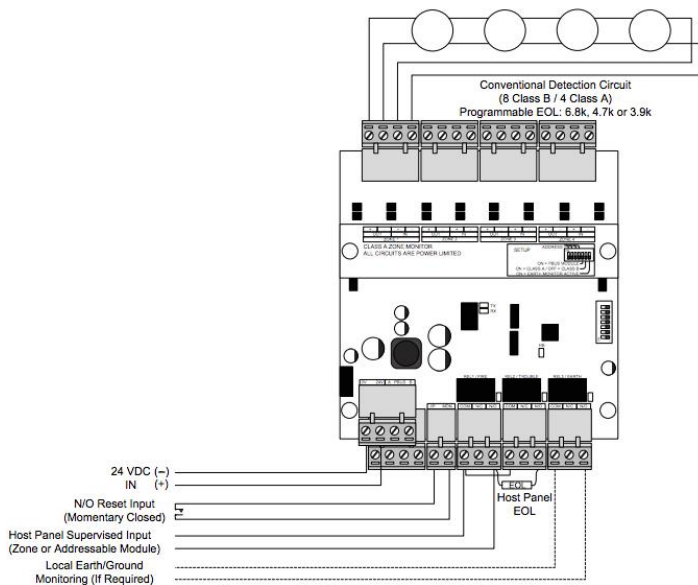

AX-CZM Host Panel Wiring

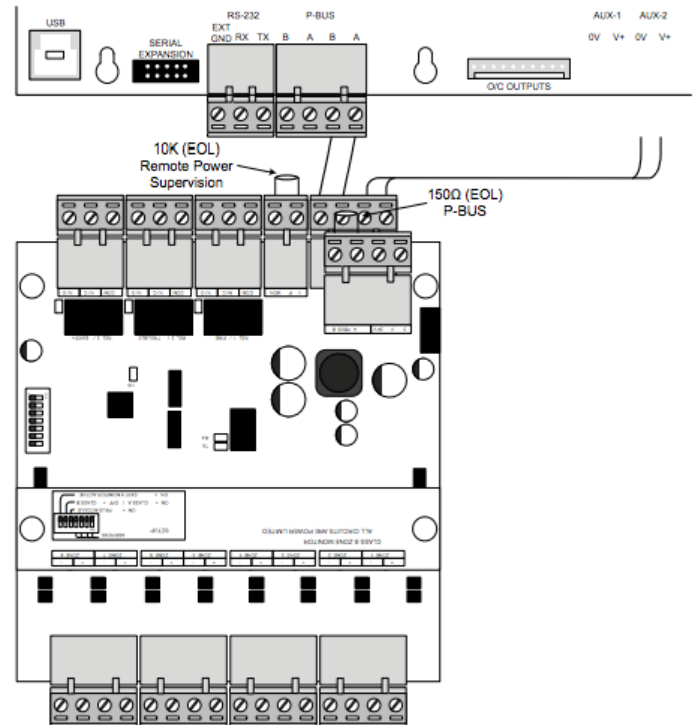

AX-CZM P-BUS Wiring

Order Codes and Options

AX-CZM	Conventional Zone Module
AXM-009*	Peripheral bus enclosure (Supports 2 x AX-CZM)

*For the gray enclosure, add the suffix **-G** to the part number.

[Check if this document is up to date](#) | [Give us feedback](#)

Advanced, The Bridges, Balliol Business Park, Newcastle upon Tyne, NE12 8EW, UK **T:** +44 (0)345 894 7000, **E:** enquiries@advancedco.com,
W: www.advancedco.com

As our policy is one of constant product improvement the right is therefore reserved to modify product specifications without prior notice.