

Intelligent Single Loop Fire Alarm Control Panel

Axis AX is built on years of technology leadership in the intelligent fire systems market, and it is used across the globe in some of the most challenging and prestigious locations. Axis AX is Advanced's highest performing UL 864 compliant panel range and comes complete with digital audio.

The state of the art Axis AX single loop panel is available in two configurations, the compact AX-CTL-1, and the standard sized AX-CTL-1L. The single loop panel contains the same features as the 2 loop and 4 loop Axis AX panels and is ideally suited to smaller applications. However, as a member of the Axis AX Series, it can be easily utilized in larger applications due to its integral peer-to-peer networking capabilities.

Designed with installation and service engineers in mind, the AX-CTL-1 (1L) intelligent panel is modularly packaged, using surface mount and dual flash microprocessor technology, with onboard real time clocks for ease of installation, troubleshooting, programming, and maintenance.

The AX-CTL-1 (1L) Intelligent Single Loop Fire, Alarm Control Panel, provides a single Style 4 or Style 6/7 Signaling Line Circuit (SLC). Communications to the field devices attached to the SLC is via an advanced, 100% digital protocol with advantages of being highly immune to noisy environments. The SLC supports up to 126 analog addressable devices (any combination of intelligent detectors, input and/or output devices, including loop powered technology devices). In addition, unique sub-addressing of various input and/or output devices is permitted, expanding on overall AXCTL-1 (1L) system capacity.

The AX-CTL-1 (1L) comes with two filtered, voltage regulated Notification Appliance Circuits (NACs), Class A or B, each rated 2 Amp @ 24 VDC. Due to exceptional regulation and high rating, the onboard NAC outputs provide compatibility with most Listed notification appliance devices.

The AX-CTL-1 (1L) intelligent panel has resettable and non-resettable power outputs; each rated .5 Amp @ 24 VDC, for connection to four-wire conventional smoke detectors and/or ancillary devices. Each AX-CTL-1 (1L) contains three, field programmable, Form "C" relays, each rated 1 Amp @ 30 VDC, defaulted as a fail-safe trouble relay, alarm relay, and supervisory relay.

Simplifying and reducing initial system set-up, each AX-CTL-1 (1L) Intelligent Single Loop Fire Alarm Control Panel is equipped with an installer-friendly "Auto-Learn/ Loop Detection" feature that permits the rapid recognition of all signaling line circuit devices. This rapid recognition simplifies the assignment of critical life safety functions immediately. Assignments include intelligent detector type and operation criteria, addressable input device recognition as an alarm input and addressable output control on a general alarm basis.



Features

- 126 Analog Addressable Points
- Advanced User Interface with Graphical LCD
- "Dynamix" I/O Relationship Programming
- Multi-Pattern & Two-Stage NAC Control
- Remote Diagnostic Virtual Panel Simulator
- AD-NeT-PluS Peer-to-Peer Networking
- Automatic Drift Compensation per Detector
- Automatic Detector Testing with Maintenance Alert
- Alarm Verification and PAS
- SLC Circuit Compatibility with Xtralis VLC-400
- Style 4, 6 & 7 SLC Operation (Supports loop powered technology)
- Class A or B NAC Circuits
- Voltage Regulated NACs (Compatible with most Listed NAC devices)
- Synchronization of Audibles and Visuals (Panel or network wide)
- "Auto-Learn/Loop Detection" Programming
- Built-in Intelligent Multi-Meter
- Optional ipGateway for text and email status notification
- Optional Integral or Portable Printer

Designed with powerful built-in installation and customization tools, the AX-CTL-1 (1L) Intelligent Single Loop Fire Alarm Control Panel can adapt to virtually any application requirement. With DynamiX programming, typical time-consuming complexities associated with I/O relationship programming such as two-stage multi-pattern NAC control, intelligent detector drift compensation, precision response/sensitivity mode settings, flexible timing functions, and more, are sharply reduced.

The AX-CTL-1 (1L) intelligent panels are fully field programmable via the onboard graphical LCD display and alphanumeric keypad. Front panel programming may encompass defining input to output relationships, configuring output circuit characteristics, entering zone, device, and other text descriptions, and configuring multiple user-access passwords.

To maximize the capability and flexibility of the AX-CTL-1 (1L) Intelligent Single Loop Fire Alarm Control Panel and to expand upon the customization of an installation, the Advanced Windows based PC-NeT field configuration tool is available. The PC-NeT field configuration tool is a powerful, user-friendly programming tool that allows users to perform virtually any I/O relationship with multiple criteria. Simple drop-down menus with point-and-click operation make project commissioning and troubleshooting fast and efficient.

Designed with the technician in mind, each module of the AX-CTL-1 (1L) intelligent panel is easy to install and service. The integral power supply offers status LEDs, temperature compensated charging, and the ability to operate directly from the batteries when AC supply is not yet available at the installation site. A unique built-in intelligent multimeter allows technicians to interrogate any input and/or output and diagnose potential time-consuming trouble issues with virtually no complications or aggravation. With an AX-CTL-1 (1L) intelligent panel, servicing a customer after installation can be as simple as using the Advanced Remote Diagnostic Virtual Panel Simulator and/or ipGateway (AX-LAN). The simulator can be activated from any Windows based PC and connected to the installation site via a dedicated modem.

The Remote Diagnostic Virtual Panel Simulator emulates the on-site control panel LCD and keypad in real time from an off-site location. The simulator is an incredibly powerful tool for diagnosing and troubleshooting site applications. The ipGateway (AX-LAN) provides real-time text and email alerts of system status.

Listings and Approvals

- ETL ANSI/UL 864 Listed: 3118002NYM-001B
- CSFM Approved: 7165-1713:0101
- NYC FD COA #6080

Graphical Liquid Crystal Display Navigation Buttons

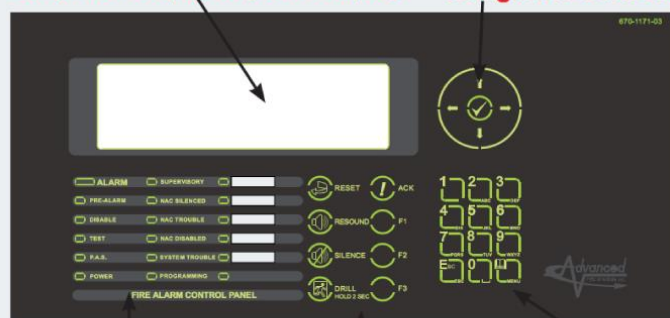

LED Status Indicators Control Buttons 12 Button Keypad (Numbers & Letters)

Advanced User Interface w/Graphical LCD:

Designed to be user-friendly and easy to operate, the Advanced User Interface w/Graphical LCD (backlit 240 x 64) is the information and control center for the AX-CTL-1 (1L) Intelligent Single Loop Fire Alarm Control Panel.

The unit incorporates a graphical LCD display, LED status indicators, control buttons (including 3 programmable buttons), navigation buttons, and a 12 button keypad for complete system status, interrogation, and control.

Button (Keys)

	Reset
	Ack (panel buzzer acknowledge)
	Resound (resound signals)
	Silence (silence signals)
	Fire Drill
	Function Keys (3 - programmable control buttons)
	Navigation Keys (up, down, left, right, and tick [enter])
	12 Button Keypad (numbers, letters, esc, and menu)

LED Indicators

Alarm	Red
Pre-Alarm	Red
Disable	Yellow
Test	Yellow
P.A.S.	Yellow
Power	Green
Supervisory	Yellow
NAC Silenced	Yellow
NAC Trouble	Yellow
NAC Disabled	Yellow
System Trouble	Yellow
Programming	Yellow
Programmable LED 1	Red
Programmable LEDs 2-5	Yellow

Specifications

Operating Voltage	120 VAC (1.4A) - 240 VAC (0.7A), 50/60Hz	
System-Brown-Out	98 VAC Nominal	
Battery Circuit		
Charging Voltage	27.4 VDC Nominal	
Temp. Compensated Charging Current	2 Amp	
Battery Derating Factor	0.83A	
Battery Capacity	7Ah (minimum), 48Ah (maximum)	
Battery Fuse	5A @ 240 VAC, Time Delayed, Ceramic.	
Fire, Supervisory, and trouble relays	(Power Limited - When utilizing system power)	
Type	Form "C"	
Rating	1A @ 30 VDC/VAC	
Trouble Relay	Normally Active (Fail-safe operation)	
Auxillary Power Outputs	(Power Limited)	
Resettable		
Voltage	24 VDC	
Current	0.5A	
Reset time	10-15 Seconds	
Non-resettable		
Voltage	24 VDC	
Current	0.5A	
Humidity	85% Relative Humidity	
Temperatures		
Operating	32°F - 120°F (0°C - 49°C)	
Recommended Room	60°F - 86°F (15°C - 27°C)	
Enclosure Dimensions		
AX-CTL-1	19.1"H x 16"W x 5.3"D	
AX-CTL-1L	24.1"H x 16"W x 6.3"D	
SLC Loop	(Power Limited)	
Class (Style)	Class A or B (Style 4, 6 or 7)	
Voltage	24 VDC	
Minimum Return Voltage	17 VDC	
Current	0.5A	
NAC circuits	(Power Limited)	
Class (Style)	Class A or B	
Voltage	24 VDC (Filtered and regulated)	
Minimum Return Voltage	16 VDC	
Current	2A (Each)	
Maximum Voltage Drop	3 VDC	
Maximum Line Impedance	1.5Ω	
Baud Rate	9600	
Parity	None	
Data Bits	8	
Stop Bits	1	
Base Card Operating Current	Quiescent	Alarm
AX-CTL-1(L)	110mA	195mA

* Refer to individual Axis AX series module datasheets for specific specifications regarding option modules

Wiring Diagram

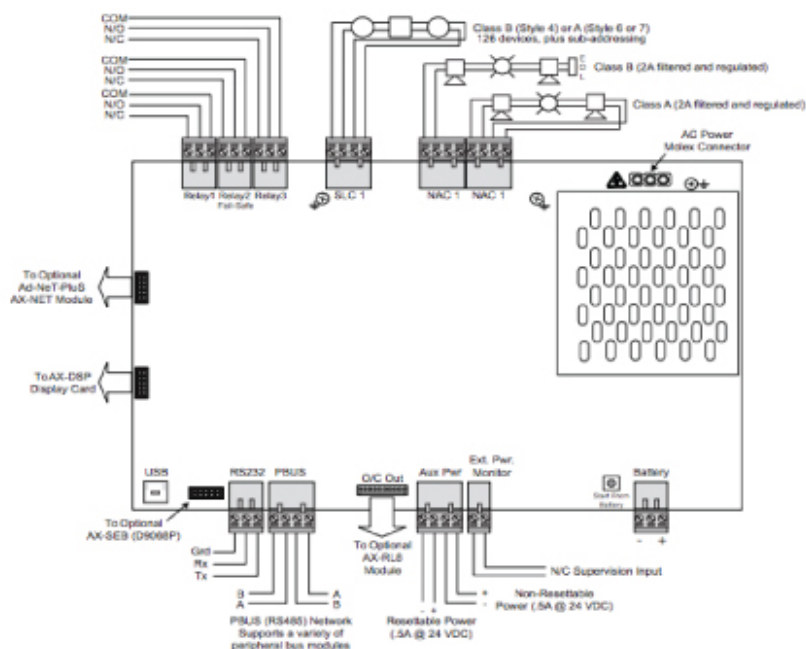

Order Codes and Options

AX-CTL-1*	Intelligent Single Loop Fire Alarm Control Panel with compact enclosure, power supply/charger, 1 SLC, 2 NACs, 3 auxiliary relays (Enclosure supports batteries 7Ah - 18Ah)
AX-CTL-1L*	Intelligent Single Loop Fire Alarm Control Panel with standard Axis AX Series enclosure, power supply/charger, 1 SLC, 2 NACs, 3 auxiliary relays (Enclosure supports batteries 7Ah - 18Ah)
	AX-CTL Base Card Option Modules**:
AX-NET4	Network Interface Card (Style 4)
AX-NET7	Network Interface Card (Style 7)
AX-RL8	8-Way Relay Output Card (Programmable)
AX-012	Thermal Strip Printer
AX-SEB/D9068P	Serial Expansion Board and Serial Digital Alarm Communicator

* For the gray enclosure, add the suffix "G" to the part number.

** Refer to individual Axis AX Series module data sheets for peer to peer network and peripheral bus optional modules.

[Check if this document is up to date](#) | [Give us feedback](#)

Advanced, The Bridges, Balliol Business Park, Newcastle upon Tyne, NE12 8EW, UK T: +44 (0)345 894 7000, E: enquiries@advancedco.com,
W: www.advancedco.com

As our policy is one of constant product improvement the right is therefore reserved to modify product specifications without prior notice.