

## Intelligent NAC Module

Advanced Intelligent NAC Module is an addressable module for use with the Axis AX Series Intelligent Fire Alarm Control Panel's SLC Loops. Each module incorporates an independent, individually programmable, notification appliance circuit (NAC), providing cost-effective solutions in areas requiring multiple notification appliance circuits. Each NAC module allows switching of an external power supply, such as a 24 VDC regulated power source or audio amplifier to a group of notification appliances.

The notification appliance circuit can be wired either Class A or B. Each module also supervises the wiring for opens, shorts and grounds and reports this status back to the intelligent fire alarm control panel. Typical input power to the NAC module would be from the main FACP, a power supply booster or an amplifier.

To increase the already rapid response activation, each module can be set to a group address, allowing all NAC modules assigned to a common group address to be activate from a single command poll from the intelligent fire alarm control panel.

An eight position programming DIP switch is provided on each NAC module for NAC circuit addressing and wiring classification definition. An additional four position programming DIP switch is provided for group addressing. The NAC module mounts to the front of a standard 4" square or 2-gang electrical outlet box. Displayed on the front of each module is a single red status LED that flashes when the module is polled.

Compatible with the Axis AX Series Dynamix I/O relationship programming, the NAC module can be individually assigned to activate from any input zone or address. In addition, the NAC module can be programmed with various output relationships, timing functions, gated functions, etc. to perform project specific control operations.



### Features

- Class A or B Wiring
- Horn/Strobe or Speaker Control
- Flexible Programmability
- Durable Construction
- Cost-Effective & Trouble-Free Installation
- 25/70 VRMS Speaker Capability
- 4" Square or 2-Gang Electrical Outlet Box Mounting
- Power Limited

### Listings and Approvals

- CAN/ULC-S527-11 & CAN/ULC-S559-04 Listed: 100780709NYM-001
- ULC Listed: UOXXC.S24460

## Wiring Diagram

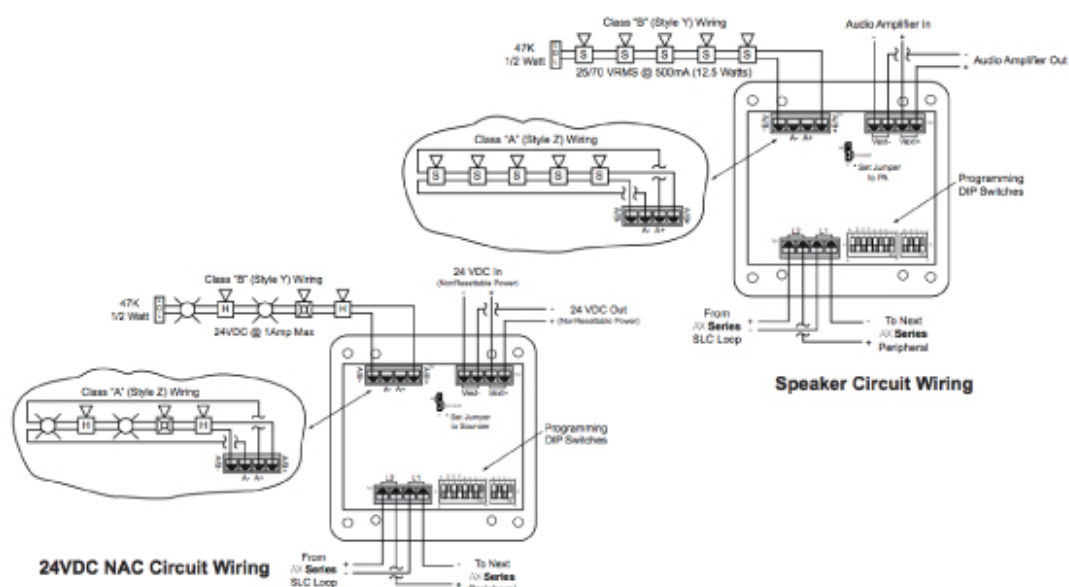

## Specification

Voltage	17-28 VDC, with Communication Pulses 5-9 VDC
Operating Current	1 mA (Quiescent) 1 mA (Alarm) 6 mA (With LED's)
Line Impedance	50 $\Omega$
Wiring Classification	Class A or B
End-of-Line Resistor	47 K $\Omega$ , 0.5 Watt (Class "B" Only)
Circuit Voltage Input	24 VDC or 25/70 VRMS
Max NAC Circuit Line Loss	24VDC @ 1 Amp (Use Regulated DC Listed Supply)
Max Speaker Circuit Output	24VDC, 25 /70.7VRMS @ 500mA
Wiring Terminals	Screw In-Out Terminals
Mounting	4" Square or 2-Gang Electrical Outlet Box
Dimensions (Diameter & Height)	4 1/2"W x 4 1/2"H x 1"D
Weight	2.8 oz
Operating Temperature	32 °-120 °F (0o -49 °C)
Humidity	10 - 93% (Non-Condensing)

## Order Codes and Options

55000-825AFC	Notification Appliance Circuit Module
--------------	---------------------------------------

[Check if this document is up to date](#) | [Give us feedback](#)

Advanced, The Bridges, Balliol Business Park, Newcastle upon Tyne, NE12 8EW, UK T: +44 (0)345 894 7000, E: [enquiries@advancedco.com](mailto:enquiries@advancedco.com),  
W: [www.advancedco.com](http://www.advancedco.com)

As our policy is one of constant product improvement the right is therefore reserved to modify product specifications without prior notice.