

WP-2000 Enclosure

The WP-2000, Weatherproof Duct Detector Enclosure, is for use with an SL-2000 Series Conventional Duct Detector. The enclosure offers outdoor protection of a SL-2000 Conventional Duct Detector from rain, sleet, and snow or indoor protection from dripping water.



Features

- 16 Gauge Steel
- Drip Shield Top
- Slip-on Removable Cover
- Embossed Mounting Holes
- 3 Knockouts in Bottom of Enclosure
- UL 50 Type 3R / NEMA Type 3R Enclosure
- Egg Shell White Finish
- Foam Gaskets for Sampling/Exhaust Ports

Listings and Approvals

Installation Diagram

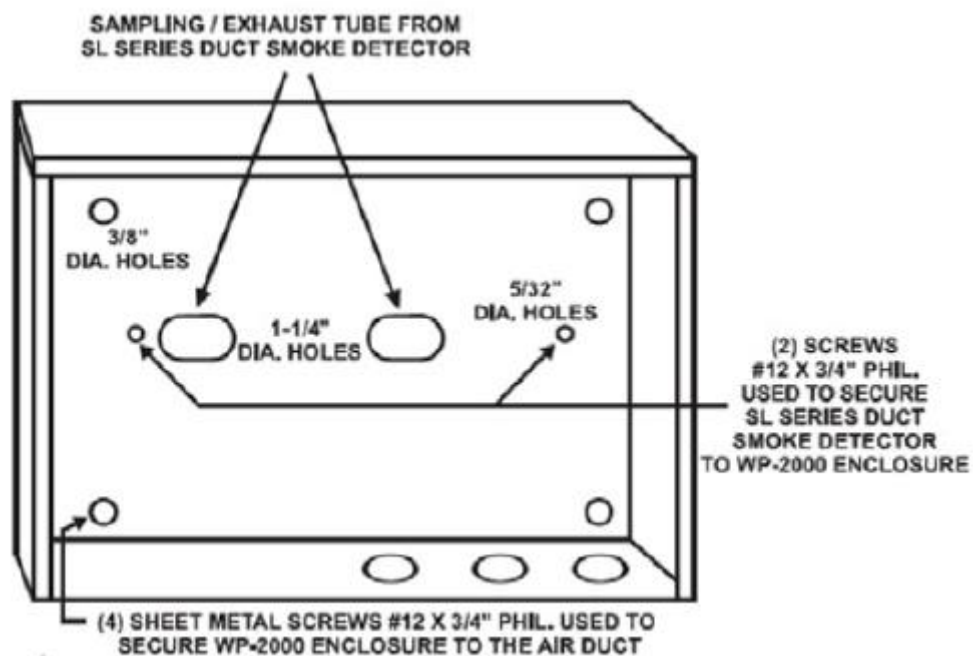

Specification

Dimensions	11.06" H x 18.13" W x 4.38" D
Knockouts	3 bottom, convertible 0.75" to 1.75"
Metal	16 gauge CRS
Access	2 screws, removable cover
Protection Rating	3R - UL 50, NEMA and CSA
Temperature	See SL-2000 series data sheet

Order Codes and Options

WP-2000	Weatherproof Duct Detector Enclosure
---------	--------------------------------------

[Check if this document is up to date](#) | [Give us feedback](#)

Advanced, The Bridges, Balliol Business Park, Newcastle upon Tyne, NE12 8EW, UK T: +44 (0)345 894 7000, E: enquiries@advancedco.com,
W: www.advancedco.com

As our policy is one of constant product improvement the right is therefore reserved to modify product specifications without prior notice.